

Any questions? Call us on +353 (0)1 247 9007

PM2 Activation

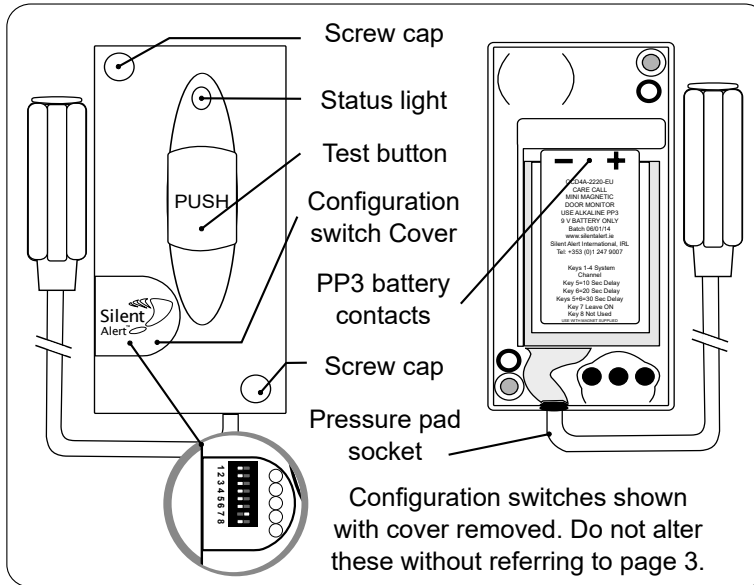

1. Install a 9 volt PP3 alkaline or lithium battery making sure to observe the correct polarity.

When a battery is first fitted the indicator light will flash red then green a few times.

The light then will flash green several times to show the battery voltage.
9 flashes = 9Volts in the battery.

If the light flashes red at this point the battery is flat and will need to be replaced.

To repeat the battery check remove the battery, press the test button then re-insert the battery to start the sequence again.

2. The monitor is activated using an under carpet pressure pad (PM2).

Plug the PM2 plug into the socket on the monitor.

The connection can be taped for added security if required.

The monitor may transmit the first time the connection is made, this is normal.

3. Place the pad under the carpet ensuring the pad is not folded.

WARNING
When installing the pad make sure the cable can't cause a trip hazard.

4. The pad can be placed under a rug at a doorway or beside a bed

5. As the user stands on the carpet directly above the pad the monitor will send a signal to the Pager or SignWave.

Quick start guide Mini Monitor with Lead Mobile Phone Detection



Mobile phone activation

Any questions? Call us on +353 (0)1 247 9007

B9250 mobile phone sensor

Available from Action on Hearing Loss
<https://www.actiononhearingloss.org.uk>

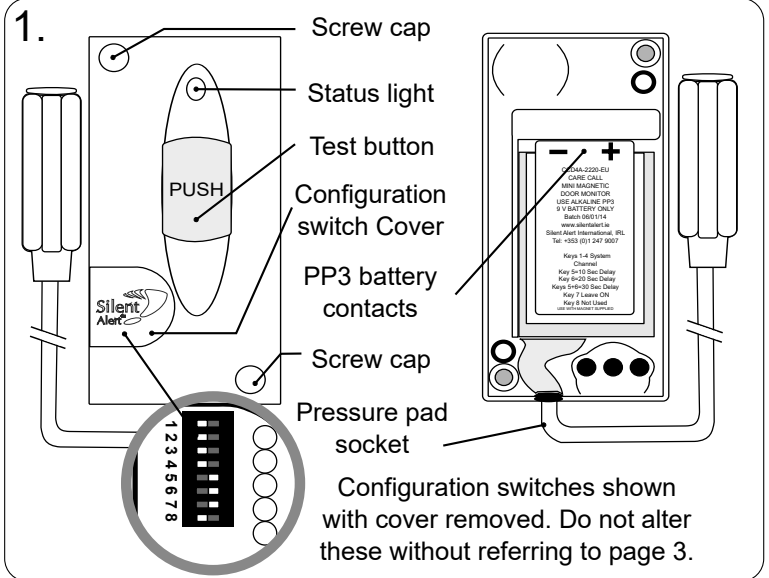
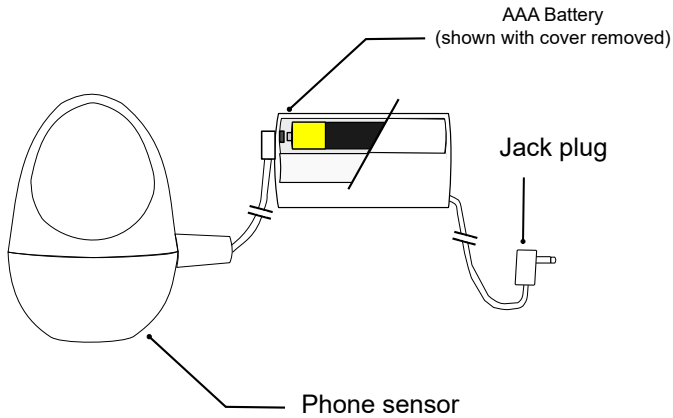

2. Install a 9 volt PP3 alkaline or lithium battery making sure to observe the correct polarity.

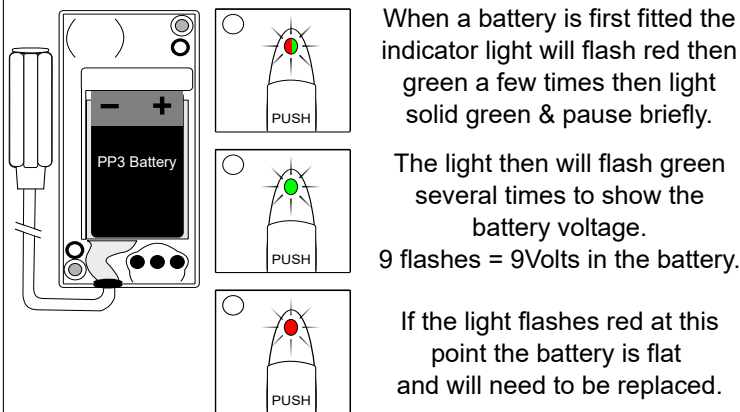

To repeat the battery check remove the battery, press the test button then re-insert the battery to start the sequence again.

3. The monitor is activated using a jelly bean switch.

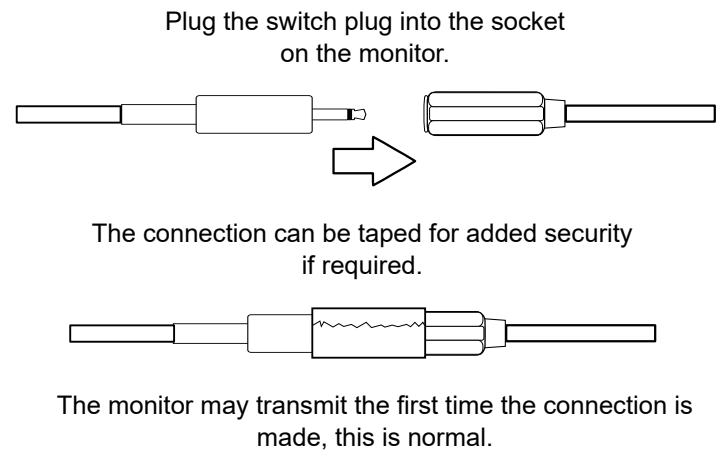

4. Place the sensor onto your device's screen.

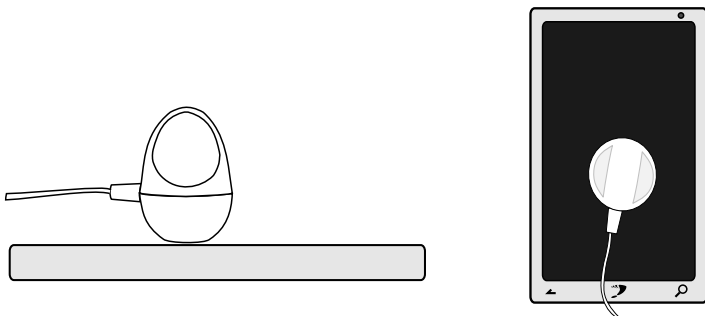

WARNING

When installing the sensor make sure the cable doesn't cause a trip hazard.

5. When you receive a call the display will illuminate and trigger the Mini Monitor.

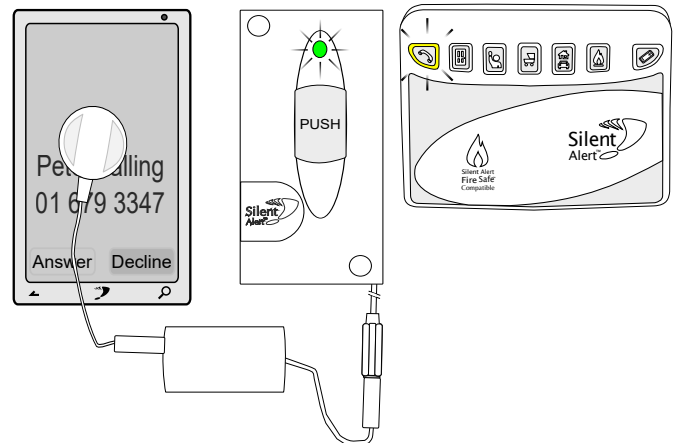

Advanced settings MM4A-2212-EU-LEAD

Mini Monitor with Lead



Any questions? Call us on +353 (0)1 247 9007

It is possible for the monitor to light up different keys on the Pager or SignWave. This allows more than one mini monitor to be used on a SA3000 system.

Move the relevant key to the right .

Press the test button and check the correct event is received by the Pager or SignWave.

Key 7 must be left on.

Changing the system channel code

NOTE. In most cases it is not necessary to change the system code. However, when one or more systems are in close proximity, system codes can be used to avoid interference from other SA3000 systems using up to a maximum of 16 channels.

The monitor is supplied with no system code switches set (system code 1). For reference this is the factory setting should you need to re-set the unit.

System codes can be set using key switches 1 - 4.

The diagram to the right shows the 16 possible combinations.

KEY 7 MUST BE LEFT ON!

Be sure that the same system code is set on the receiver to be used and any other monitoring options in that system.